



Applies To: 1997 Prelude – ALL

April 21, 1997

Whistle From Windshield

SYMPTOM

A whistling sound from the top, center area of the windshield at highway speeds.

PROBABLE CAUSE

The upper windshield molding is vibrating.

CORRECTIVE ACTION

Apply sealant under the upper windshield molding.

REQUIRED MATERIALS

Masking tape (at least 2 inches wide)

3M Black Super Silicone Sealant:
3M P/N 051135-08662

3M General Purpose Adhesive Cleaner:
3M P/N 051135-08984

WARRANTY CLAIM INFORMATION

In warranty: The normal warranty applies.

Operation number: 824701

Flat rate time: 0.5 hour

Failed part: P/N 73150-S30-003
H/C 5206743

Defect code: 056

Contention code: B07

Out of warranty: Any repair performed after warranty expiration may be eligible for goodwill consideration by the District Service Manager or your Zone Office. You must request consideration, and get a decision, before starting work.

DIAGNOSIS

Drive the vehicle at highway speeds, and listen for a whistling sound. While driving, push up against the top of the windshield in front of the rearview mirror; if the sound changes, go to **REPAIR PROCEDURE**.

048807

REPAIR PROCEDURE

1. To protect the roof, apply masking tape (at least 2 inches wide) along the edge of the entire upper windshield molding.

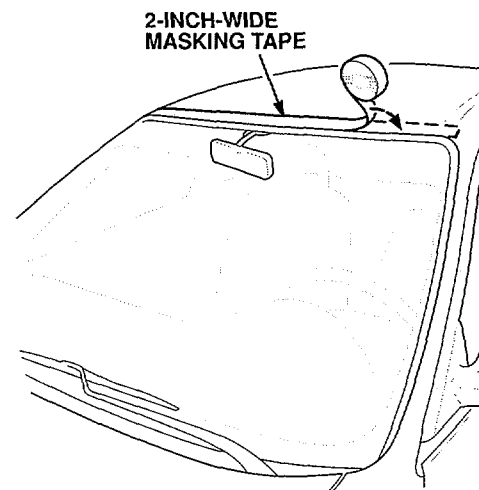

2. Pull up the upper windshield molding using an O-ring pick or similar tool, and apply 3M Black Super Silicone Sealant under the entire molding.

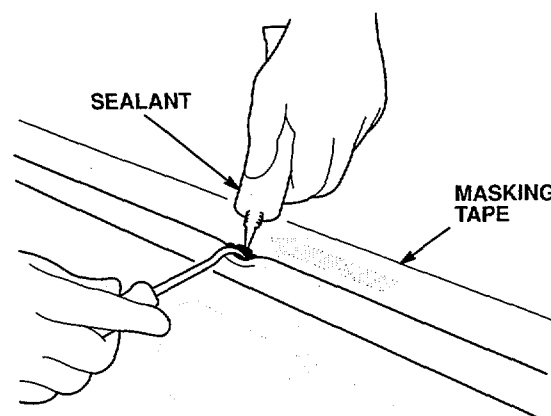

3. Press the rubber molding to smooth it out and make sure it sits flush.
4. Allow the sealant to set for about 5 minutes. Remove the masking tape, and clean up any excess silicone with 3M General Purpose Adhesive Cleaner.